

HL7009A

3.6A I²C Controlled Single Cell Battery Charger with OTG

Overview

HL7009A is a simple fully integrated switch-mode Li-ion battery chargers providing 3.6A max charge current for single cell. The charge will charge the battery without power path management, which will provide low cost and compact charging solutions for smart phones, tablets, power banks and other portable devices. To further reduce the cost and size and increase the charging efficiency, the charger removes the charge current sense resistor and uses unique sense method to get accuracy charge current control. Internal power switches are optimized to get high efficiency with different input voltage which will reduce the charging time.

HL7009A supports a wide range of input sources, including standard USB host port, USB charging port and AC-DC adapter. It supports an input operating voltage from 4.0V to 9.5V and can power up the system rail without a battery. It can support BC1.2 detection which can get proper input current limit to get fully use of the power provided by the input source.

HL7009A can manage the complete charging cycle of a Li-ion battery autonomously with the presence of an I²C host. It detects the battery voltage and automatically charges the battery in three phases: pre-charge, constant current, and constant voltage. It automatically terminates charging when the battery is fully charged and re-starts a charging cycle if the battery voltage falls below the recharge threshold. It's I²C interface provides maximum programmability for charging parameters and system-level communication. When the I²C host is not present, a built-in watchdog timer stops charging after the timer expires to assure safety battery operation.

HL7009A supports OTG function which will provide configurable output voltage at VBUS, the max output current can get up to 1.2A.

HL7009A integrates comprehensive protections mechanism to ensure safe operation, including input over voltage and under voltage, VBAT over voltage, inductor over current, thermal regulation and thermal shutdown etc.

HL7009A is available in a compact 1.6mm x 2.0mm WLCSP-20 package.

Features

- Support 4.0V- 9.5V operating voltage
- High Efficiency 3.6A switching charger.
 - ✓ >92% efficiency at 9V input 4V/3A output with 1uH/30mohm inductor
- USB compliant input current limit
 - ✓ USB1.0/2.0/3.0 compliant input current limit
 - ✓ 0.1A to 2.5A programmable input current limit with 100mA step
- Autonomous preconditioning/CC/CV/termination charger control and auto recharge.
- Programmable switching frequency 0.85MHz/1.2MHz/1.7MHz
- 3.9V to 9V input voltage regulation range
- No external sense resistor required.
- Accuracy over temperature
 - ✓ ±0.5% charge voltage regulation
 - ✓ ±10% charge current regulation for 1.5A-2A charge current setting.
 - ✓ ±200mA charge current regulation for 2A-3.6A charge current setting.
- Integrated reverse boost.
 - ✓ 5.0V to 5.45V output voltage with ±3% accuracy.
 - ✓ 0.5A/1.2A constant output current limit.
 - ✓ Startup with 300uF capacitive load.
- Comprehensive protections
 - ✓ VBUS over voltage protection
 - ✓ VBAT over voltage protection
 - ✓ Reverse battery leakage protection
 - ✓ Switches over current protection
 - ✓ Thermal regulation and thermal shutdown
 - ✓ VOTG output over voltage protection
 - ✓ OTG overload protection
 - ✓ Safety timer and watchdog timer
- 1.6mm x 2.0mm WLCSP-20 package

Applications

- Smart phone
- Tablet PC
- Mobile IOT devices

Simplified Application Diagram

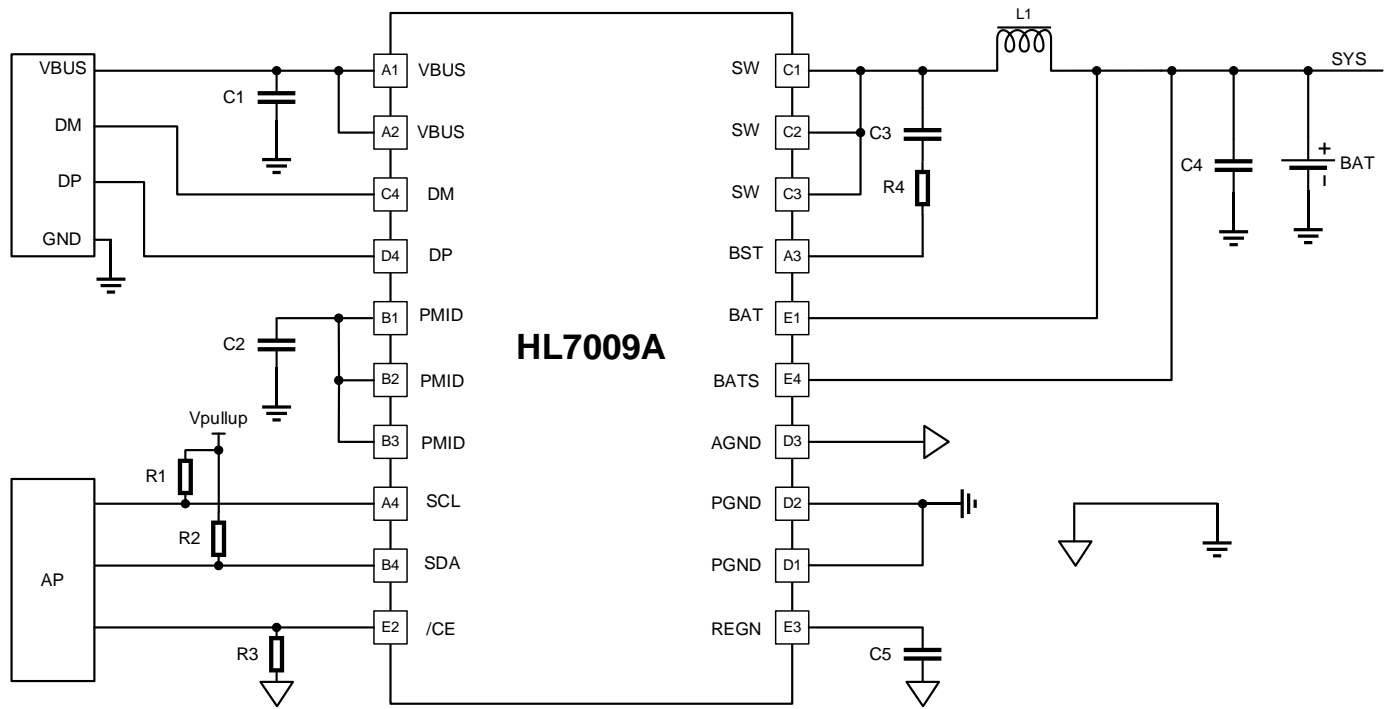

Ordering Information

Part Number	Package	Size
HL7009AWL01	WLCSP-20	1.6mm x 2.0mm

Important Notice

Halo Microelectronics reserves the right to modify, improve, and terminate its products, services, documentations, etc. without advance notice. Customers are encouraged to contact Halo Microelectronics sales representatives to get the latest product information.

Without proper legal authorization, Halo products shall not be used for medical or military applications. Halo Microelectronics does not assume any liability of personal or property damages of any kind due to such applications.

All text, images, trademarks of this document, and any intellectual property contained in the product and in this document belong to Halo Microelectronics Co. Ltd. No part of this document may be used, copied, modified, distributed, or published without legal authorization from Halo Microelectronics.

© 2024 Halo Microelectronics. All rights reserved. www.halomicro.cn